

FLANGE HOG 110®

Hand Operated
Flange Facing Tool



*Recondition RF and FF
flange gasket seat surfaces
with a precise phonograph
finish in minutes!*

esco tool®

FLANGE HOG 110®

Hand Operated Flange Facer
0.900" I.D. to 14" O.D.
22.86mm I.D. to 355.6mm O.D.

Manually Operated Flange Facing Tool Delivers Precise Phonographic Finish On RF and FF Gasket Seats

Key Features

- Manually operated, no electrical, hydraulic, or air lines necessary
- Smooth swing operation produces perfectly precise phonographic finish
- I.D. clamping range of .9" to 10.3" with facing diameter up to 14"
- Accurately mounts to the flange I.D. in seconds
- Feeds available for both smooth and stock finish in accordance with ASME B16.5 standards
- Cutting tool has both neutral (straight) and 90 degree tool bit holders
- Made of high strength precision machined materials
- Sturdy carry / transport case for managing all components
- Available kits come ready to use
- Strong hardware that is easy to use and makes setup fast
- Saves time and money
- For Sale and Rent

Flange facing made easy with the FLANGE HOG 110®

The FLANGE HOG 110® is a rugged, compact and ideal for quickly reconditioning rusty, scarred and worn flange gasket seats to like-new condition in minutes. This easy to operate flange facing tool is perfect for re-facing RF and FF flanges on site, in a fabrication/repair shop and it produces a perfectly precise phonographic finish.

The FLANGE HOG 110® has a clamping range from .9" (22.86mm) to 10.3" (261.6mm) and can machine flanges with a reach up to 14" (355.6mm) O.D. The ESCO proprietary clamping system is simple to configure and designed for fast set-up with accurate alignment.

Cutting bits are double sided, long lasting, and specially formed to cut through a wide variety of material including carbon steel, stainless steel, alloyed steel, aluminum and cast iron.

Each tool kit comes ready to use in a sturdy carrying case that keeps everything conveniently organized and readily accessible.

Whether you are interested in buying or renting, the FLANGE HOG 110® will provide you with the consistently accurate results and years of trouble free service.



Proprietary I.D. clamping components ensure quick and accurate fit-up.



Draw rod wrench and knurled knob give the tool a comfortable ergonomic feel.



Alignment accuracy is easily achieved by ESCO's clamp rib and pad system.



Double sided insert provides long lasting clean finishes job after job.

FLANGE HOG 110®

Hand Operated Flange Facer
 0.900" I.D. to 14" O.D.
 22.86mm I.D. to 355.6mm O.D.



Flange Machining Diameter Range

.9" - 14"
22.9mm - 355.6mm

Inside Diameter Clamping Range

.895" - 10.391"
22.7mm - 263.9mm

Weight Ready-To-Use

15.4 lbs.
7 Kg.

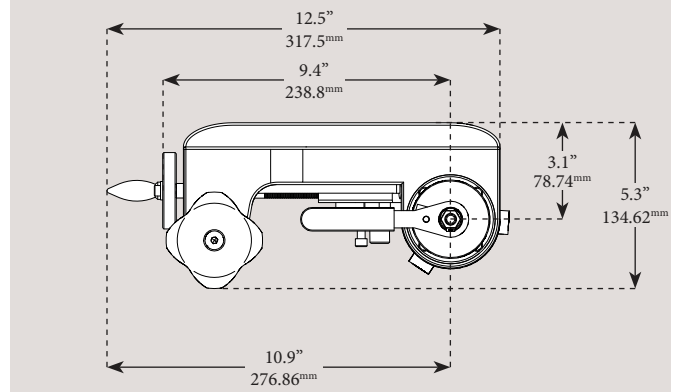
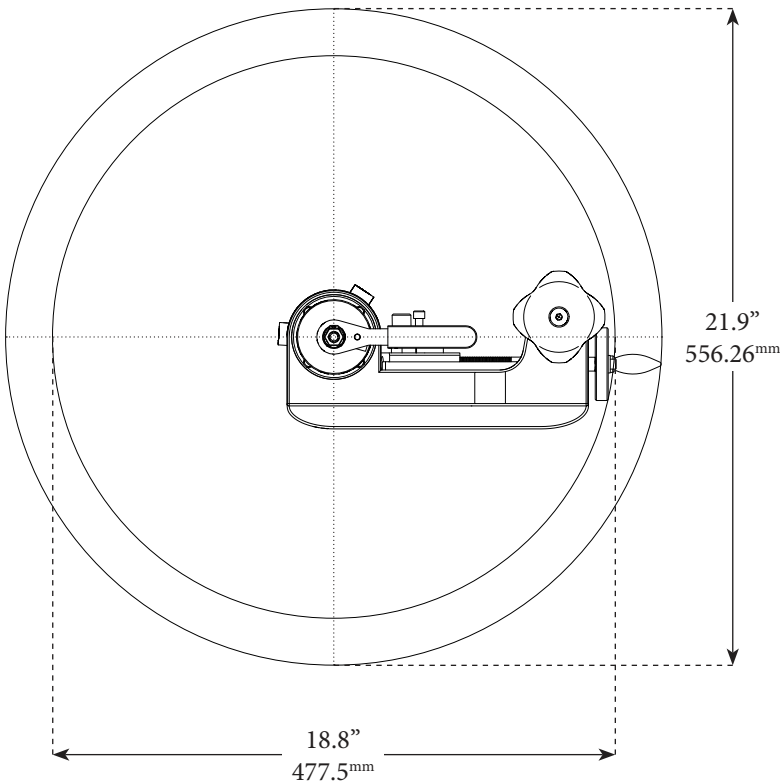
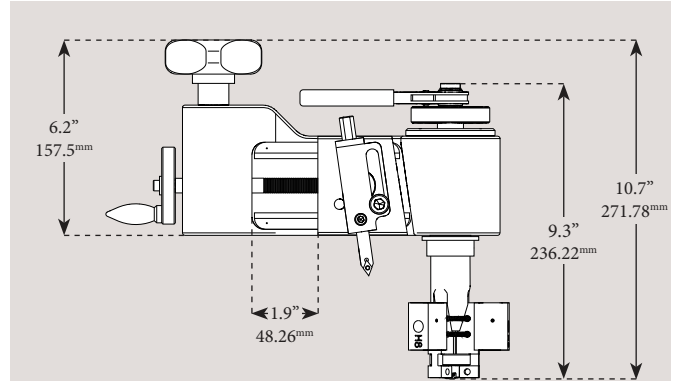

Clamping Advantage

The FLANGE HOG 110® uses one mandrel and two wedges to achieve the full clamping range of .9" (22.9mm) to 10.391" (263.9mm). This rugged proprietary clamping system is simple to set-up and attaches to the flange I.D. with consistent unmatched accuracy. All components are made of high strength precision machined materials for long service.

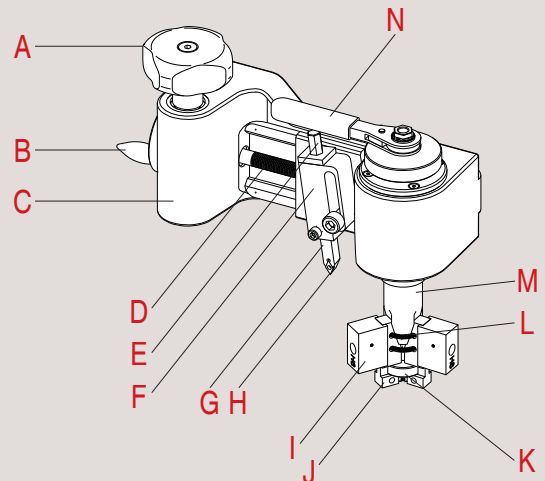

- | | |
|----------------------------|-------------------------|
| A. Knob | H. Insert, 1/4" |
| B. Positioning Knob Handle | I. Clamp Pad |
| C. Housing | J. Clamp Rib |
| D. Feed Shaft | K. Actuator |
| E. Index Nut | L. Spring |
| F. Tool Post Assembly | M. Wedge |
| G. Insert Holder, Straight | N. Clamp Release Wrench |

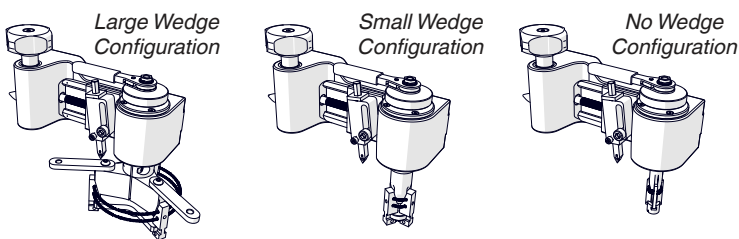

MILLHOG[®]

Precision Pipe and Tube
Beveling, Cutting, and Fabricating Tools

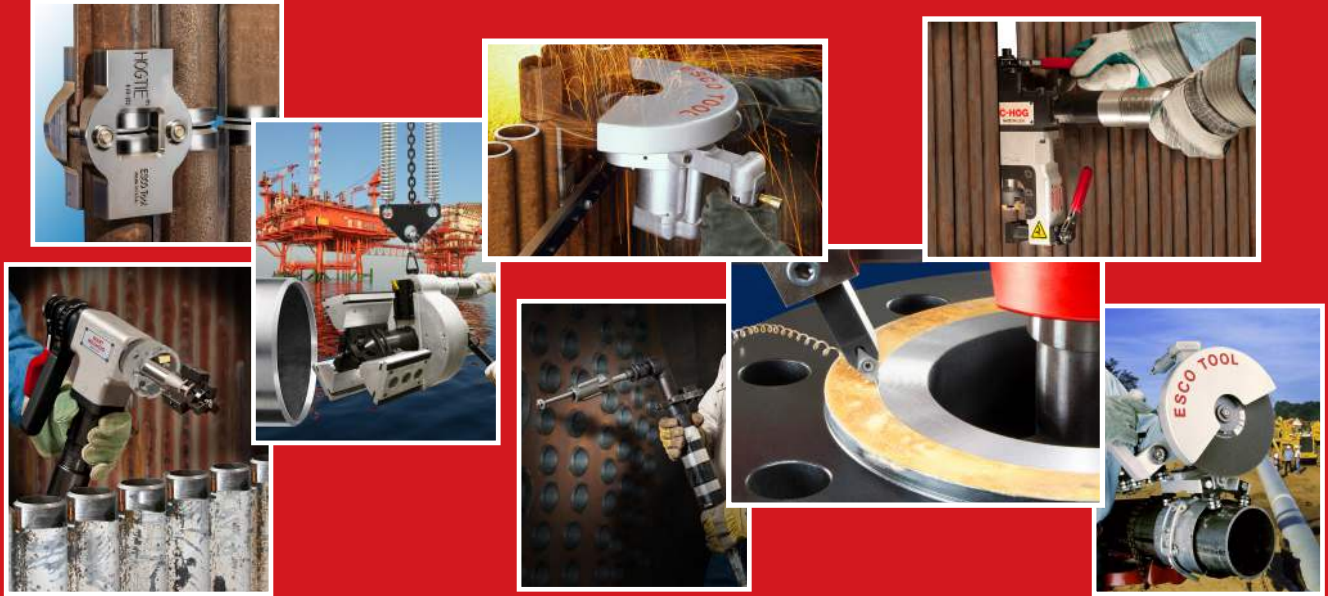

Manufacturer and Market Leader
We Deliver Cutting Edge Innovation



esco tool[®]

ESCO TECHNOLOGIES, INC.

75 October Hill Road • Holliston, MA 01746 USA

1.508.429.4441 • fax 1.508.429.2811

email: millhog@escotool.com

Available for Sale or Rent • www.escotool.com

Contact us or your local representative
to schedule a demo today